

**Fantic,**  
we design,  
engineer  
and assemble  
high-performance  
electric bikes.

Fantic USA, Inc.  
InfoUSA@fantic motor.it  
[Fantic.com](http://Fantic.com)  
Facebook/FanticUSA

E-Bike Brochure

FANTIC

EN

**E-Bike  
Brochure**

A woman wearing a black Fantic t-shirt, black shorts, a silver helmet, and pink sunglasses is riding a Fantic e-bike on a dirt trail. The bike is black with bright yellow and red accents. She is leaning forward in a riding posture. The background shows a clear blue sky and some greenery.

Company	02
Fantic philosophy	04
E-Bikes overview	06
E-MTB Light Rampage XC/DC	09
E-MTB Trail	15
E-MTB All Mountain	21
E-MTB Enduro	25
E-MTB Downhill	31
E-MTB Hardtail	37
Issimo and Trekking	41
Specifications	53



**Fantic** is a brand with more than 50 years of history.

We design, engineer and assemble high-performance electric bikes, with a view to enhancing our customers' experience. We focus on **design & technology** without compromise. We are a powerful e-motion.



# Fantic philosophy

01

## Autonomy

Fantic designs its **E-Bikes** with a view to ensuring the best **performance of the battery and electric motor**. New integrated 720Wh Battery / compact 369mm 40-cell battery. **The Rosenberg magnetic connector ensures a long lifespan** even when operated under high loads. We have introduced a dedicated management system to optimize battery consumption.

02

## Handling

Fantic designs its E-bikes assuring the best performance of the battery and electric motor. The new integrated 720 Wh Battery is a compact (14.5 inch) 40 cell battery. Our E-Mtbs are engineered to have a short integrated battery (14.5in vs 15.75in of the competition) reducing the yaw inertia and lowering the center of gravity provides for an easier change of direction. **Optimized Motor & Battery layout**. Powertrain at the center of the bike enhancing weight distribution & lowering yaw inertia. A 29" wheel to safely overcome bigger obstacles and reduce gyro effect to further improve easy change of direction. **Advanced hydroforming for high stiffness of the frame**, rigid rear triangle achieved through forged cantilever, oversized bearings, single pivot configuration and oversized chain stays. FEM analyzed and optimized top bar, down bar, steering tubes, and junctions. Rigid front triangle for predictable handling.



## Exclusivity

UX Design & Engineering **made in Italy**. All **E-Bikes** (Frames, Group sets & Powertrains) fully designed, engineered & assembled in Europe (Italy & Germany). **Exclusive new 720 Wh battery designed by Fantic**. Based on over 50 years of expertise, engineering & Italian design, **Fantic** bikes provide the end-consumer with the best experience available on the market. Battery upper release. Prevents: having a dirty battery, hitting the ground when releasing it or having to place the bike upside down to remove it.

03

## Control

The rear suspension linkage features **FPS (Fantic Progression System)**, to ensure excellent grip performance on any terrain. In collaboration with **Acerbis**, our R&D department has designed and developed an **'injected composite'** rear chainstay strut. This novel technology not only allows the brace to perform and respond better and more quickly on uneven terrains compared to other materials, but also instantly gives it a new look. This innovative technology will be applied to the Trail Alu, All-Mountain, Enduro and DH segments. Our engineers carefully select the **motors we use to offer the best torque even at a low pedalling cadence** (between 60-90 pedal strokes per minute), up to a maximum torque of 120 Nm (\*). The choice of combined 29/27.5-inch wheels are the result of **Fantic's** expertise in the motorcycle industry delivering unrivaled control. (\*) In the *Issimo 45* model.



Control



Handling



Exclusivity



Autonomy

\*The bike in the photo refers to the **Rampage 1.4 Factory** model.



05

**E-MTB  
Light  
Rampage  
XC/DC  
Pag. 09**



Rampage 1.2 Race



Rampage 1.4 Factory



Rampage 1.4 Sport

**E-MTB  
Hard  
Tail  
Pag. 37**



Fat Sport



Integra XF2



Rampage 1.4 Limited Edition

**Issimo  
and  
Trekking  
Pag. 41**



Issimo Urban

**E-MTB  
Trail  
Pag. 15**



XTF 1.5 Carbon



XTF 1.5 All Track



XTF 1.5



Living



Living Easy

**E-MTB  
All  
Mountain  
Pag. 21**



XMF 1.7 Carbon Sport



XMF 1.7



Seven Days Living



Seven Days Living Easy

**E-MTB  
Enduro  
Pag. 25**



XEF 1.9 Factory



XEF 1.9 Race



XEF 1.9 Carbon Team

**E-MTB  
Downhill  
Pag. 31**



XXF 2.0 Factory



XXF 2.0 Race



# E-MTB Light Rampage XC/DC



Preferring **long distances and extreme speeds** to unleash a load of pure adrenaline on cross country routes embodying the essence of its name: **Rampage** – the first e-mtb light by **Fantic**.

You get to choose between 2 travel range types: XC (120mm) or DC (140mm).

The innovative **Rampage**, designed with a focus on lightness by **Fantic's** R&D department, boasts a **full carbon frame** weighing just 34lbs (\*) in its high-end version.

Its seamlessly integrated battery makes it easy to forget its presence.

(\*)The ebike referenced in the weight is the **Rampage 1.2 Factory**.



# Rampage 1.2 Race

Colour options:  
red

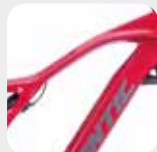













App



**Technical specifications**

Color: **black**

-  Full-Carbon, sizes: S-M-L-XL
-  SRAM GX Eagle AXS Transmission, 12s, 10-52
-  TQ HPR-50, Torque/Coppia: 50 Nm
-  Magura MT8 PRO 2 Piston disc brake (Front & Rear)
-  TQ integrated, Lithium Ion, 360Wh
-  Mavic Crossmax SL Ultimate 29" (Front & Rear)
-  RockShox SID Ultimate 2P 120mm Remote lock
-  Pirelli SCORPION ProWall XC-RC - 29"x 2.2 (Front & Rear)
-  RockShox SIDLuxe 2P Ultimate Remote lock
-  Selle Italia SLR Boost Superflow
-  Fantic Racing Integrated Flat-17°, 780mm
-  Crankbrothers Highline 11 Ø30.9 - carbon

# Rampage 1.4 Sport

Colour options:  
red

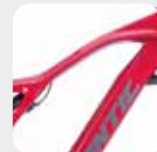













App



**Technical specifications**

Color: **black**

-  Full-Carbon, sizes: S-M-L-XL
-  SRAM SX Eagle, 12s, 11-50
-  TQ HPR-50, Torque/Coppia: 50 Nm
-  SRAM LEVEL 2 Piston disc brake
-  TQ integrated, Lithium Ion, 360Wh
-  GBC Radiale 29" (Front & Rear)
-  Suntour RAIDON34 LOR
-  Vittoria SYERRA - 29"x 2.4 (Front & Rear)
-  Suntour EDGE PLUS 2CR
-  Selle Italia Model-X Superflow
-  GBC Ø31,8 FLAT
-  RST ELEV8 A2 Ø30.9





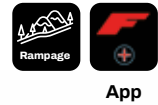
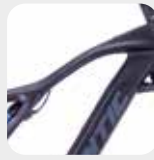







# Rampage 1.4 Factory

Colour options:  
black



**Technical specifications**

Color: **red**

-  Full-Carbon, sizes: S-M-L-XL
-  SRAM GX Eagle AXS Transmission, 12s, 10-52
-  TQ HPR-50, Torque/Coppia: 50 Nm
-  Magura MT8 PRO 2 Piston disc brake
-  TQ integrated, Lithium Ion, 360Wh
-  Mavic Crossmax SL S 29" (Front & Rear)
-  Suntour AXON34 LO-RC PCS Factory
-  Vittoria SYERRA - 29"x 2.4 (Front & Rear)
-  Suntour EDGE PLUS 2CR
-  Selle Italia Novus Boost X-Cross Superflow
-  Fantic Racing Integrated Flat 17°, 780mm
-  RockShox Rverb AXS



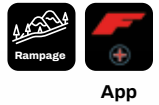









# Rampage 1.4 Limited Edition



**Technical specifications**

**Note:** (\*) Product shown with water bottle and TQ Range Extender, both of which are sold separately as accessories.

Color: **white**

-  Full-Carbon, sizes: S-M-L-XL
-  SRAM GX Eagle AXS Transmission, 12s, 10-52
-  TQ HPR-50, Torque/Coppia: 50 Nm
-  Magura MT8 PRO, 2 Pistons
-  TQ integrated, Lithium Ion, 360Wh
-  FSA KFX Carbon - 29" (Front & Rear)
-  FOX 34 FACTORY, 140mm - orange
-  Vittoria SYERRA - 29"x 2.4 (Front & Rear)
-  FOX FLOAT FACTORY, 190x45mm
-  Selle Italia Novus Boost X-Cross Superflow
-  FSA KFX UD Carbon Ø31,8 flat 760mm
-  FOX TRANSFER FACTORY





# E-MTB Trail



The **Trail** range includes three different models for the US market with both carbon fiber and aluminum frames, all fully suspended with 150 mm front travel

They are fitted with **Brose or Yamaha** motors in order to achieve the best possible performance.

**All Fantic frames are designed and developed in-house** by strictly applying our four design principles (handling, control, autonomy, and exclusivity) to produce high-performing and adrenaline-pumping bikes.



# XTF 1.5 All Track

Colour options:  
green



Colour options:  
silver

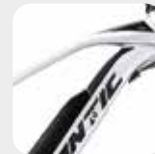

# XTF 1.5



App



App



**Technical specifications**

Seatstays made of "injected composite"

Color: **grey**

 Aluminum, sizes: S - M - L

 SRAM SX Eagle, 12s, 11-50

 <sup>90Nm</sup> Yamaha PW X3, Torque/Coppia: 85 Nm

 SRAM Level 2 Piston disc brake

 Fantic, Lithium Ion, 36 Volt, 630Wh

 Rodi TRYP30 - 29" (Front & Rear)

 RockShox Recon Silver RL 150mm

 Pirelli Scorpion ProWall Trail (Front & Rear)

 RockShox Deluxe Select

 Selle Italia MODEL-X Comfort Superflow 145

 Promax-760mm Rise 18mm-Ø31,8

 Switch SW Ø30.9

**Technical specifications**

Color: **yellow**

 Aluminum, sizes: S - M - L

 SRAM SX Eagle, 12s, 11-50

 <sup>90Nm</sup> Brose S-Alu, Torque/Coppia: 90 Nm

 SRAM Level 2 Piston disc brake

 Fantic, Lithium Ion, 36 Volt, 630Wh

 Rodi TRYP30 - 29" (Front & Rear)

 RockShox Recon Silver RL 150mm

 Pirelli Scorpion ProWall (Front & Rear)

 RockShox Deluxe Select

 Selle Italia Model-X Comfort Superflow 145

 Promax teles. SP -2038 Ø 30.9, S 80mm / M-L 100mm

 Promax teles. SP -2038 Ø 30.9, S 80mm / M-L 100mm

# XTF 1.5 Carbon















Colour options:  
cool gray



## Technical specifications

Color: **lime**

 Carbon, sizes: S - M - L - XL	 SRAM NX Eagle, 12s, 11-51
 90 Nm Brose S-Mag 36, Torque/Coppia: 90 Nm	 SRAM GUIDE T 4 Piston disc brake
 Fantic, Lithium Ion, 36 Volt, 720Wh	 Rodi READY27- 29" (Front & Rear)
 RockShox 35 Gold RL 150mm	 Pirelli Scorpion ProWall Trail (Front & Rear)
 RockShox Deluxe Select+	 Selle Italia Model-X Comfort Superflow 145
 FSA 760mm- Ø31,8 Rise 15mm - Sweep 6°	 Switch SW Ø 30.9





# E-MTB All Mountain



**MTB All Mountain** by **Fantic**,  
the keyword is **versatility!**

Designed to offer an excellent balance between downhill performance and uphill pedalling, the **All Mountain** range consists of 2 models, 1 with a carbon frame and 1 in aluminium, both fully suspended for maximum shock absorption with a 170 mm travel.

**Engineered and developed by Fantic** for those who are looking for a **high-performance and versatile bike**, and suitable for all types of trails and paths, from those with little elevation gain to more challenging descents.



# XMF 1.7 Alloy

Colour options:  
military green



App



**Technical specifications**

Color: **white**

Aluminum, sizes: S - M - L	SRAM NX Eagle, 12s, 11-50
90 Nm Brose S-Mag 36, Torque/Coppia: 90 Nm	SRAM Guide T 4 Piston disc brake
Fantic, Lithium Ion, 36 Volt, 720Wh	Front: Fulcrum E-Fire 700 29" Rear: Fulcrum E-Fire 700 27.5"
RockShox Domain R 170mm	Front: Vittoria E-MARTELLLO 29"x 2.35 Rear: Vittoria E-MARTELLLO 27,5"x 2.6
RockShox Deluxe Select+	Selle Italia Model X Comfort Superflow 145
FSA Comet-800mm Ø35 - Rise 15mm	Switch SW Ø 30.9 S-M, L

# XMF 1.7 Carbon Sport



App



**Technical specifications**

Color: **carbon black**

Carbon, sizes: S - M - L	SRAM GX Eagle, 12s, 11-50
90 Nm Brose S-Mag 36, Torque/Coppia: 90 Nm	SRAM Code R 4 Piston disc brake
Fantic, Lithium Ion, 36 Volt, 720Wh	Front: Fulcrum E-Fire 700 29" Rear: Fulcrum E-Fire 700 27.5"
Suntour DuroLux 38	Front: Vittoria E-MARTELLLO 29"x 2.35 Rear: Vittoria E-MARTELLLO 27,5"x 2.6
RockShox SuperDeluxe Select+	Selle Italia X Bow Superflow
FSA Grid - 800mm Ø35 - Rise 15mm	Switch SW Ø 30.9



# E-MTB Enduro



**E-MTB Enduro by Fantic,  
power at your service!**

Designed for natural descents, new school trails, bike parks and aggressive slopes, the **Enduro** range includes the Race and Factory versions. The second one is characterized by **carbon seatstays**, and they are all fully suspended for maximum shock absorption with a 180 and 190 mm travel.

**Engineered and developed by Fantic** for those who are looking for an extremely high-performance bike that is agile and reliable both on steep slopes and on bumpy terrain, but also rideable and allows you to reach the top thanks to the long-life 720Wh battery.



# XEF 1.9 Factory

Colour options:  
**white**

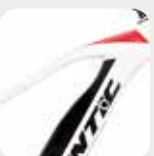

Colour options:  
**military green**



# XEF 1.9 Race



App



App















Color: **military green**















Color: **white**

**Technical specifications**

 Aluminum, sizes: S - M - L	 SRAM GX Eagle AXS, 12s, 11-51 Cassette SunRace Silver Red
 <sup>90 Nm</sup> Brose S-Mag 36, Torque/Coppia: 90 Nm	 BRAKING First, 2 Piston disc brake
 Fantic, Lithium Ion, 36 Volt, 720Wh	 Front: Mavic E-Deemax 29" Rear: Mavic E-Deemax 27.5"
 RockShox Zeb Ultimate 190mm	 Front: Vittoria E-MAZZA 29"x 2.6 Rear: Vittoria E-MARTELLLO 27,5"x 2.8
 Ohlins TTX 22M	 Selle Italia Novus Boost X Cross Superflow
 Fantic Racing-800mm Ø35 - Rise 20mm -Sand	 Crankbrothers HIGHLIGHT7 Ø 30.9

**Technical specifications**

 Aluminum, sizes: S - M - L	 SRAM GX Eagle, 12s, 11-50
 <sup>90 Nm</sup> Brose S-Mag 36, Torque/Coppia: 90 Nm	 Magura MT7 4 Piston disc brake
 Fantic, Lithium Ion, 36 Volt, 720Wh	 Front: Mavic E-Deemax 29" Rear: Mavic E-Deemax 27.5"
 RockShox Zeb Select 190mm	 Front: Vittoria E-MAZZA 29"x 2.6 Rear: Vittoria E-MARTELLLO 27,5"x 2.8
 RockShox SuperDeluxe Coil Select+	 Selle Italia Model-X Bow Superflow
 FSA Gradient - 800mm Ø35 - Rise 15mm	 Crankbrothers HIGHLIGHT7 Ø 30.9 S-M, L

# XEF 1.9

## Carbon Team











App



### Technical specifications

Color: **Red**

 Carbon, sizes: S - M - L	 SRAM GX Eagle, 12s, 12s, 11-50
 Brose S-Mag 36, Torque/Coppia: 90 Nm	 Magura MT7 4 Piston disc brake
 Fantic, Lithium Ion, 36 Volt, 720Wh	 Front: Mavic E-Deemax 29" Rear: Mavic E-Deemax 27.5"
 RockShox Zeb Ultimate 190mm	 Vittoria E-Mazza 29" x 2.6 Vittoria E-Martello 27.5" X 27.6
 RockShox SuperDeluxe Coil Select+	 Selle Italia Novus Boost Evo Superflow
 FSA Gradient - 800mm Ø35 - Rise 25mm	 SWITCH SW Ø30.9





# E-MTB Downhill



**E-MTB Downhill,**  
fast as the wind!

Fantic's **Downhill** product for the US market is the Factory version characterized by **carbon seat stays** and 200mm of travel.

**Designed and developed by Fantic** for those who are looking for extremely high performance and light weight, but also robustness to guarantee the rider excellent driving efficiency and an extraordinary speed.



# XXF 2.0 Factory

Colour options:  
**white**



Colour options:  
**military green**



# XXF 2.0 Race



App



**Technical specifications**

Color: **military green**

 Aluminum, sizes: S - M - L	 SRAM GX Eagle, 12s, 11-51 Cassette SunRace Silver Red
 Brose S-Mag 36, Torque/Coppia: 90 Nm	 BRAKING First, 2 Piston disc brake
 Fantic, Lithium Ion, 36 Volt, 720Wh	 Front: Mavic E-Deemax 29" Rear: Mavic E-Deemax 27.5"
 Ohlins DH 38 200mm	 Front: Vittoria E-MAZZA 29"x 2.6 Rear: Vittoria E-MARTELLLO 27,5"x 2.8
 Ohlins TTX 22M	 Selle Italia Novus Boost X Cross Superflow
 Fantic Racing - 800mm Ø35 - Rise 30mm - Sand	 Crankbrothers HIGHLIGHT7 Ø 30.9















App



**Technical specifications**

Color: **white**

 Aluminum, sizes: S - M - L	 SRAM NX Eagle, 12s, 11-50
 Brose S-Mag, Torque/Coppia: 90 Nm	 Magura MT7 4 Piston disc brake
 Fantic, Lithium Ion, 36 Volt, 720Wh	 Front: Mavic E-Deemax 29" Rear: Mavic E-Deemax 27.5"
 RockShox Boxxer Select, 200mm	 Front: Vittoria E-MAZZA 29"x 2.6 Rear: Vittoria E-MARTELLLO 27,5"x 2.8
 RockShox SuperDeluxe Coil Select+	 Selle Italia Model-X Comfort Superflow
 FSA Gradient - 800mm Ø35 - Rise 25mm	 Switch SW Ø 30.9



# E-MTB Hard Tail



Designed for hilly or wooded trails, dirt tracks or dirt roads, the **Hard Tail** range is composed of 2 models, **Integra XF2** and **Fat**, front suspended with 120 mm travel only on the front.

**Engineered and developed by Fantic** for those who are looking for a simple, sporty and also high-performing bike without too much effort. In the spotlight is the Fat Sport model, one of a kind and characterized by wide tires for use on snow.



# Fat Sport

# Integra XF2













App



**Technical specifications**

Color: **sage green**

 Aluminium, sizes: S - M - L	 SRAM SX Eagle, 12s, 11-50
 Brose T-Alu, Torque/Coppia: 70 Nm	 SRAM Level, 2 Piston, Hydraulic Disc Brake, 200/180mm disc
 Fantic, Lithium Ion, 36 Volt, 630Wh	 Gipiemme 26" (Front & Rear)
 RockShox Bluto, 120mm	 Schwalbe JUMBO-JIM, 26 X 4"
 FSA Ø31,8 - 760m - Rise 15mm	 Selle Italia Model X Comfort superflow
	 FSA Ø30.9











App



**Technical specifications**

Color: **red**

 Aluminium, sizes: S - M - L	 Sram SX Eagle, 12s, 11-50
 Brose T-Alu, Torque/Coppia: 70 Nm	 SRAM Level, 2 Piston, Hydraulic Disc Brake, 200/180mm disc
 Fantic, Lithium Ion, 36 Volt, 630Wh	 Gipiemme, tubeless ready
 RockShox Recon Silver RL, 120mm	 Front: Vittoria Barzo 29"x 2.25" Rear: Vittoria Barzo 27.5" x 2.6"
 FSA Ø31,8 - 760m - Rise 15mm	 Selle Italia Model X Comfort superflow
	 Rigido FSA Ø30.9



# ISSIMO



The product range is completed with the **award-winning Issimo Urban**, which has reinvented the concept of sustainable mobility, revolutionizing commuting by making it both easier and safer. **Issimo** guarantees **safety and stability** on every terrain, thanks to its 20x4" tires and low center of gravity.

# Trekking



Fantic's engineers have designed this model to integrate our best **Italian design**, innovative lines, top level performance and all the road safety we need. **Fantic** has created a new "concept" of urban E-Bikes that is suitable for every kind of road, and is sporty and contemporary.

Riding every day, in the city and outdoor areas, without compromising on safety, quality and comfort. That's why we created the world of **Living**, one model for **everyday commuting, for everyone.**



# Issimo Urban

Colour options:

white

silver

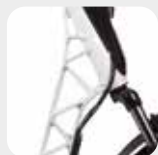

App available only in the Issimo "Urban Connect" model.



Color: **black**

### Technical specifications

	Aluminum frame, Unix Design, One Size		16Th Chain rings
	Bafang M500, Torque/Coppia: 95 Nm		Radius BH-M960
	Fantic, Lithium Ion, 36 Volt, 630Wh		Gipiemme 20" Fat
	Zoom 80mm		Vee-Tire Co - 20"X4" Speedster

# Issimo

10 colorful covers

\*



# Living

# Living Easy



App



**Technical specifications**

Color: sand

Aluminium, sizes: S - M - L	SRAM SX Eagle, 12s, 11-50
Yamaha PW S2, Torque/Coppia: 75Nm	Promax Solve ST 925 hydraulic 2P, 180mm disc (Front & Rear)
Fantic, Lithium Ion, 36 Volt, 630Wh	GBC 29" (M-L) - 27.5" (S)
Suntour XCR34, travel 100mm	Vittoria E-Randonneur 50mm
GBC 700mm, Rise 20mm	Selle Italia S5 Superflow
	Switch Suspended Ø30.9



App



**Technical specifications**

Color: blue

Aluminium, sizes: S-M / L-XL	Sram SX Eagle, 12s, 11-50
Yamaha PW S2, Torque/Coppia: 75Nm	Promax Solve ST 925 hydraulic 2P, 180mm disc (Front & Rear)
Fantic, Lithium Ion, 36 Volt, 630Wh	GBC 29" (M-L) - 27.5" (S)
Suntour XCR34, travel 100mm	Vittoria E-Randonneur 50mm
GBC 700mm, Rise 20mm	Selle Italia MAX S5 Superflow
	Switch Suspended Ø30.9

# Seven Days Living

# Seven Days Living Easy



App



App



### Technical specifications

Aluminium, sizes: S - M - L	SRAM SX Eagle, 12s, 11-50
Brose T-Alu, Torque 70Nm	SRAM Level steel hydraulic 2P, 180mm disc (Front & Rear)
Fantic, Lithium Ion, 36 Volt, 630Wh	GBC, Aluminum, 28" (Front & Rear)
RockShox Recon 29, 100mm	Vittoria E-Randonneur, 50mm (Front & Rear)
GBC Over Back - 680mm, RISE 25mm	Selle Italia ST 5 GF
	GBC AHEAD Set over - 70MM

### Technical specifications

Aluminium, sizes: S - M - L	Sram SX Eagle, 12s, 11-50
Brose T-Alu, Torque 70Nm	SRAM Level steel hydraulic 2P, 180mm disc (Front & Rear)
Fantic, Lithium Ion, 36 Volt, 630Wh	GBC, Aluminum, 28" (Front & Rear)
RockShox Recon 29, 100mm	Vittoria E-Randonneur, 50mm (Front & Rear)
GBC Over Back - 680mm, RISE 25mm	Selle Italia ST 5 GF
	GBC AHEAD Set over - 70MM





# Specifications

## Rampage 1.4 Factory

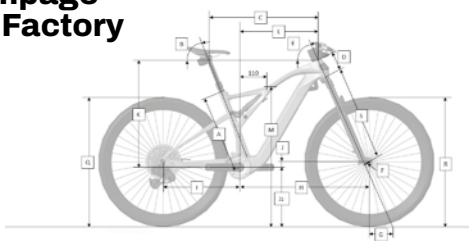

Sizes	S	M	L	XL
A	410	440	470	500
B	75.00	75.00	500	500
C	585	607	633	658
D	95	105	120	130
E	64,50	65,00	65,00	65,50
F	51	51	51	51
G	121,5	118,0	118,0	114,3
H	732	748	775	794
I	437	437	437	437
J	23	23	23	23
J <sub>2</sub>	349	349	349	349
K	605	612	627	640
L	423.5	442.5	463.0	483.0
M	795	800	805	810
N	780	780	780	780
O	65* - 70*	65* - 70*	65* - 70*	65* - 70*
P	170	170	175	175
Q/R	29" 743mm	29" 743mm	29" 743mm	29" 743mm
S	562	562	562	562
Z	100	100	125	150

\* 65 handlebar KFX SIC INTEGRATED  
\* 70 handlebar KFX FLAT

<b>Motor</b>	TQ HPR-50, Torque/Coppia: 50 Nm
<b>Battery</b>	TQ integrated, Lithium Ion, 360Wh
<b>Display</b>	TFT top tube + remote
<b>Frame</b>	Full-Carbon, Sizes: S-M-L-XL
<b>Fork</b>	Suntour AXON34 LO-RC PCS Factory
<b>Shock</b>	Suntour EDGE PLUS 2CR
<b>Chain rings</b>	Sram 34t
<b>Crank arm</b>	FSA Carbon
<b>Rear derailleur</b>	Sram GX AXS
<b>Shift Levers</b>	Sram GX AXS
<b>Cassette</b>	Sram GX, 12V, 10-52
<b>Chain</b>	Sram GX
<b>Brake</b>	Magura MT8 PRO 2 Piston disc brake
<b>Brake</b>	Magura MT8 PRO 2 Piston disc brake
<b>Disc</b>	Braking S3 Battfly, 180mm - 6Hole
<b>Disc</b>	Braking S3 Battfly, 180mm - 6Hole
<b>Tires</b>	Vittoria SYERRA - 29"x 2.4
<b>Tires</b>	Vittoria SYERRA - 29"x 2.4
<b>Wheels</b>	Mavic Crossmax SL S 29"
<b>Handlebar</b>	FANTIC RACING INTEGRATED FLAT-17", 780mm
<b>Stem</b>	nd /na
<b>Seatpost</b>	RockShox Rverb AXS
<b>Saddle</b>	Selle Italia Novus Boost X-Cross Superflow
<b>Note</b>	(*) Optional range extender, 160Wh

## Rampage 1.2 Race

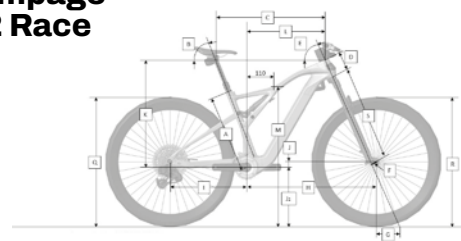

Sizes	S	M	L	XL
A	410	440	470	500
B	75.00	75.00	500	500
C	585	607	633	658
D	95	105	120	130
E	64,50	65,00	65,00	65,50
F	51	51	51	51
G	121,5	118,0	118,0	114,3
H	732	748	775	794
I	437	437	437	437
J	23	23	23	23
J <sub>2</sub>	349	349	349	349
K	605	612	627	640
L	423.5	442.5	463.0	483.0
M	795	800	805	810
N	780	780	780	780
O	65* - 70*	65* - 70*	65* - 70*	65* - 70*
P	170	170	175	175
Q/R	29" 743mm	29" 743mm	29" 743mm	29" 743mm
S	562	562	562	562
Z	100	100	125	150

\* 65 handlebar KFX SIC INTEGRATED  
\* 70 handlebar KFX FLAT

<b>Motor</b>	TQ HPR-50, Torque/Coppia: 50 Nm
<b>Battery</b>	TQ integrated, Lithium Ion, 360Wh
<b>Display</b>	TFT top tube + remote
<b>Frame</b>	Full-Carbon, Sizes: S-M-L-XL
<b>Fork</b>	RockShox SID 2P 120mm - remote lock
<b>Shock</b>	RockShox SIDLuxe 2P - remote lock
<b>Chain rings</b>	Sram 34t
<b>Crank arm</b>	FSA Forged Alloy
<b>Rear derailleur</b>	Sram GX AXS
<b>Shift Levers</b>	Sram GX AXS
<b>Cassette</b>	Sram GX, 12V, 10-52
<b>Chain</b>	Sram GX
<b>Brake</b>	Magura MT8 PRO 2 Piston disc brake
<b>Brake</b>	Magura MT8 PRO 2 Piston disc brake
<b>Disc</b>	Braking S3 Battfly, 180mm - 6Hole
<b>Disc</b>	Braking S3 Battfly, 180mm - 6Hole
<b>Tires</b>	Pirelli SCORPION ProWall XC-RC - 29"x 2.2
<b>Tires</b>	Pirelli SCORPION ProWall XC-RC - 29"x 2.2
<b>Wheels</b>	Mavic Crossmax SL S 29"
<b>Handlebar</b>	FANTIC RACING INTEGRATED FLAT-17", 780mm
<b>Stem</b>	nd /na
<b>Seatpost</b>	Crankbrothers Highline 3 Ø30.9
<b>Saddle</b>	Selle Italia Novus Boost X-Cross Superflow
<b>Note</b>	(*) Optional range extender, 160Wh

## Rampage 1.4 Sport

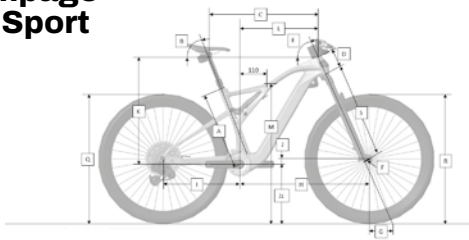

Sizes	S	M	L	XL
A	410	440	470	500
B	75.00	75.00	500	500
C	585	607	633	658
D	95	105	120	130
E	64,50	65,00	65,00	65,50
F	51	51	51	51
G	121,5	118,0	118,0	114,3
H	732	748	775	794
I	437	437	437	437
J	23	23	23	23
J <sub>2</sub>	349	349	349	349
K	605	612	627	640
L	423.5	442.5	463.0	483.0
M	795	800	805	810
N	780	780	780	780
O	65* - 70*	65* - 70*	65* - 70*	65* - 70*
P	170	170	175	175
Q/R	29" 743mm	29" 743mm	29" 743mm	29" 743mm
S	562	562	562	562
Z	100	100	125	150

\* 65 handlebar KFX SIC INTEGRATED  
\* 70 handlebar KFX FLAT

<b>Motor</b>	TQ HPR-50, Torque/Coppia: 50 Nm
<b>Battery</b>	TQ integrated, Lithium Ion, 360Wh
<b>Display</b>	TFT top tube + remote
<b>Frame</b>	Full-Carbon, Sizes: S-M-L-XL
<b>Fork</b>	Suntour RAIDON34 LOR
<b>Shock</b>	Suntour EDGE PLUS 2CR
<b>Chain rings</b>	Sram 34t
<b>Crank arm</b>	FSA Forged Alloy
<b>Rear derailleur</b>	Sram SX
<b>Shift Levers</b>	Sram SX
<b>Cassette</b>	Sram SX, 12V, 11-50
<b>Chain</b>	Sram SX
<b>Brake</b>	Sram LEVEL 2 Piston disc brake
<b>Brake</b>	Sram LEVEL 2 Piston disc brake
<b>Disc</b>	Sram CENTERLINE, 180mm - 6Hole
<b>Disc</b>	Sram CENTERLINE, 180mm - 6Hole
<b>Tires</b>	Vittoria SYERRA - 29"x 2.4
<b>Tires</b>	Vittoria SYERRA - 29"x 2.4
<b>Wheels</b>	GBC Radiale 29"
<b>Handlebar</b>	GBC Ø31,8 FLAT
<b>Stem</b>	GBC Ø31,8 x 70mm +8°
<b>Seatpost</b>	RST ELEV8 A2 Ø30.9
<b>Saddle</b>	Selle Italia Model-X Superflow
<b>Note</b>	(*) Optional range extender, 160Wh

## 1.4 Rampage Special Edition

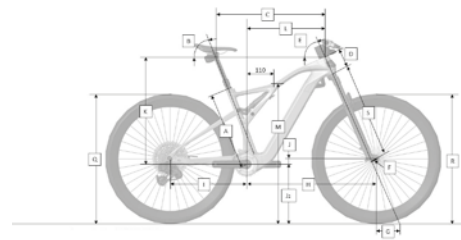

Sizes	S	M	L	XL
A	410	440	470	500
B	75.00	75.00	500	500
C	585	607	633	658
D	95	105	120	130
E	64,50	65,00	65,00	65,50
F	51	51	51	51
G	121,5	118,0	118,0	114,3
H	732	748	775	794
I	437	437	437	437
J	23	23	23	23
J <sub>2</sub>	349	349	349	349
K	605	612	627	640
L	423.5	442.5	463.0	483.0
M	795	800	805	810
N	780	780	780	780
O	65* - 70*	65* - 70*	65* - 70*	65* - 70*
P	170	170	175	175
Q/R	29" 743mm	29" 743mm	29" 743mm	29" 743mm
S	562	562	562	562
Z	100	100	125	150

\* 65 handlebar KFX SIC INTEGRATED  
\* 70 handlebar KFX FLAT

<b>Motor</b>	TQ HPR-50, Torque/Coppia: 50 Nm
<b>Battery</b>	TQ integrated, Lithium Ion, 360Wh
<b>Display</b>	TFT top tube + remote
<b>Frame</b>	Full-Carbon, Sizes: S-M-L-XL
<b>Fork</b>	FOX 34 FACTORY, 140mm - orange
<b>Shock</b>	FOX FLOAT FACTORY, 190x45mm
<b>Chain rings</b>	Sram Eagle Transmission 34t
<b>Crank arm</b>	FSA Carbon 170/175mm
<b>Rear derailleur</b>	Sram GX Eagle Transmission 12v
<b>Shift Levers</b>	Sram GX Eagle AXS
<b>Cassette</b>	Sram GX Eagle Transmission 10-52
<b>Chain</b>	Sram GX Eagle Transmission
<b>Brake</b>	Magura MT8 PRO, 2 Pistons
<b>Brake</b>	Magura MT8 PRO, 2 Pistons
<b>Disc</b>	Braking S3 Battfly 180/F-R
<b>Disc</b>	Braking S3 Battfly 180/F-R
<b>Tires</b>	Vittoria SYERRA - 29"x 2.4
<b>Tires</b>	Vittoria SYERRA - 29"x 2.4
<b>Wheels</b>	FSA KFX Carbon - 29"
<b>Handlebar</b>	FSA KFX UD Carbon Ø31,8 flat 760mm
<b>Stem</b>	FSA NS ICR 10°AO 70mm Ø31,8
<b>Seatpost</b>	FOX TRANSFER FACTORY
<b>Saddle</b>	Selle Italia Novus Boost X-Cross Superflow
<b>Note</b>	(*) Optional range extender, 160Wh

## XTF 1.5 Carbon

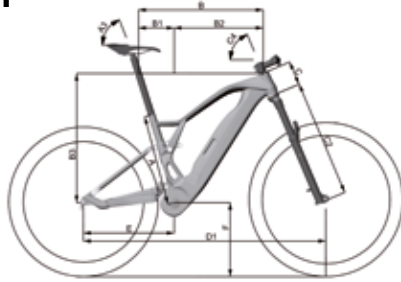

Sizes	S	M	L	XL
<b>A</b>	390	430	469	510
<b>A3</b>	73	73	73	73
<b>B</b>	575	596	628	655
<b>B1</b>	156	158	162	167
<b>B2</b>	419	438	466	488
<b>B3</b>	608,0	615,1	628,9	645,5
<b>C</b>	100	105	120	135
<b>C2</b>	568	568	568	568
<b>C4</b>	66	66,5	66,5	67
<b>D1</b>	1188	1204	1238	1260
<b>E</b>	456	456	456	456
<b>F</b>	362,5	362,5	362,5	362,5

<b>Motor</b>	Brose S-Mag 36, Torque/Coppia: 90 Nm
<b>Battery</b>	Fantic, Lithium Ion, 36 Volt, 720Wh
<b>Display</b>	Brose All Round
<b>Frame</b>	Carbon, sizes: S - M - L - XL
<b>Fork (**)</b>	RockShox 35 Gold RL 150mm
<b>Shock</b>	RockShox Deluxe Select+
<b>Chain rings</b>	Sram 34t
<b>Crank arm</b>	FSA
<b>Rear derailleur</b>	Sram NX
<b>Shift Levers</b>	Sram NX Eagle
<b>Cassette</b>	Sram SX, 12V, 11-51
<b>Chain</b>	Sram SX
<b>Brake</b>	Sram Guide T 4 Piston disc brake
<b>Disc</b>	SramCenterLine, 200mm - 6Hole
<b>Disc</b>	SramCenterLine, 180mm - 6Hole
<b>Tires</b>	Pirelli Scorpion ProWall Trail -M- 29"x 2.4
<b>Tires</b>	Pirelli Scorpion ProWall Trail -R- 29"x 2.4
<b>Wheels</b>	Rodi READY27- 29"
<b>Handlebar</b>	FSA 760mm- Ø31,8 - Rise 15mm - Sweep 6°
<b>Stem</b>	FSA Logo-60mm- Ø31,8 - Rise +6°
<b>Seatpost</b>	Switch SW Ø30.9
<b>Saddle</b>	Selle Italia Model-X Comfort Superflow 145
<b>Note</b>	(*)
	(**) Alternative fork / forcella alternativa Suntour Auron 35

## XTF 1.5 All Track

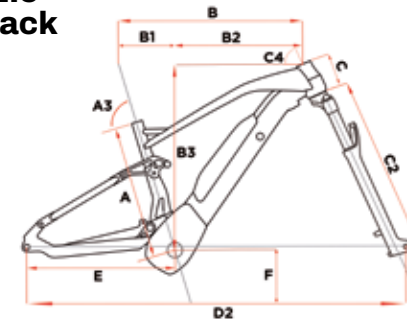

Sizes	S	M	L
<b>A</b>	390	430	490
<b>A3</b>	73	73	73
<b>B</b>	575	602	627
<b>B1</b>	166	169	174
<b>B2</b>	407	433	453
<b>B3</b>	615,8	625,0	641,5
<b>C</b>	105	115	130
<b>C2</b>	567	567	567
<b>C4</b>	66	66	66,5
<b>D1</b>	1193	1224	1244
<b>E</b>	472	472	472
<b>F</b>	358	358	358

<b>Motor</b>	Yamaha PW X3, Torque/Coppia: 85 Nm
<b>Battery</b>	Fantic, Lithium Ion, 36 Volt, 630Wh
<b>Display</b>	Yamaha Interface X
<b>Frame</b>	Aluminum, sizes: S - M - L
<b>Fork (**)</b>	RockShox Recon Silver RL 150mm
<b>Shock</b>	RockShox Deluxe Select
<b>Chain rings</b>	Sram 34t
<b>Crank arm</b>	FSA
<b>Rear derailleur</b>	Sram SX
<b>Shift Levers</b>	Sram SX Eagle
<b>Cassette</b>	Sram SX, 12V, 11-50
<b>Chain</b>	Sram SX
<b>Brake</b>	Sram Level 2 Piston disc brake
<b>Disc</b>	Sram Level 2 Piston disc brake
<b>Disc</b>	SramCenterLine, 200mm - 6Hole
<b>Disc</b>	SramCenterLine, 180mm - 6Hole
<b>Tires</b>	Pirelli Scorpion ProWall Trail -M- 29"x 2.4
<b>Tires</b>	Pirelli Scorpion ProWall Trail -R- 29"x 2.4
<b>Wheels</b>	Rodi TRYP30 - 29"
<b>Handlebar</b>	Promax-760mm-Rise 18mm-Ø31,8
<b>Stem</b>	Promax-60mm-Rise+6°-Ø31,8
<b>Seatpost</b>	Switch SW Ø30.9
<b>Saddle</b>	Selle Italia Model-X Comfort Superflow 145
<b>Note</b>	(*)
	(**) Alternative fork / forcella alternativa Suntour Auron 35

## XTF 1.5

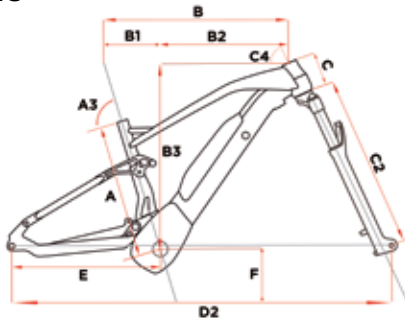

Sizes	S	M	L
<b>A</b>	390	430	490
<b>A3</b>	73	73	73
<b>B</b>	575	602	627
<b>B1</b>	166	169	174
<b>B2</b>	407	433	453
<b>B3</b>	615,8	625,0	641,5
<b>C</b>	105	115	130
<b>C2</b>	567	567	567
<b>C4</b>	66	66	66,5
<b>D1</b>	1193	1224	1244
<b>E</b>	472	472	472
<b>F</b>	358	358	358

<b>Motor</b>	Brose S-Alu, Torque/Coppia: 90 Nm
<b>Battery</b>	Fantic, Lithium Ion, 36 Volt, 630Wh
<b>Display</b>	Brose All Round
<b>Frame</b>	Aluminum, sizes: S - M - L
<b>Fork (**)</b>	RockShox Recon Silver RL 150mm
<b>Shock</b>	RockShox Deluxe Select
<b>Chain rings</b>	Sram 34t
<b>Crank arm</b>	Miranda
<b>Rear derailleur</b>	Sram SX
<b>Shift Levers</b>	Sram SX Eagle
<b>Cassette</b>	Sram SX, 12V, 11-50
<b>Chain</b>	Sram SX
<b>Brake</b>	Sram Level 2 Piston disc brake
<b>Brake</b>	Sram Level 2 Piston disc brake
<b>Disc</b>	SramCenterLine, 200mm - 6Hole
<b>Disc</b>	SramCenterLine, 180mm - 6Hole
<b>Tires</b>	Pirelli Scorpion ProWall 29"x 2.4
<b>Tires</b>	Pirelli Scorpion ProWall 29"x 2.4
<b>Wheels</b>	Rodi TRYP30
<b>Handlebar</b>	Promax Ø31,8 760mm Rise 20mm
<b>Stem</b>	Promax 60MM ±6° Ø31,8
<b>Seatpost</b>	Promax teles. SP-2038 Ø30.9, S 80mm / M-L 100mm
<b>Saddle</b>	Selle Italia Model-X Comfort Superflow 145
<b>Note</b>	(*)
	(**) Alternative fork / forcella alternativa Suntour Auron 35

## XMf 1.7 Carbon Race

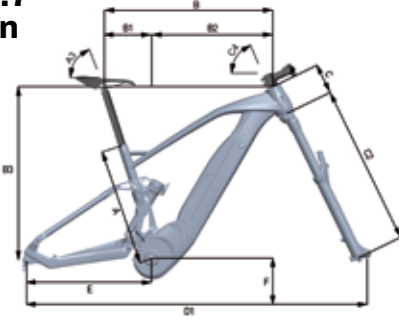

Sizes	S	M	L
<b>A</b>	390	430	490
<b>A3</b>	73	73	73
<b>B</b>	586	596	628
<b>B1</b>	161	162	166
<b>B2</b>	425	454	480
<b>B3</b>	617,8	622,0	633,7
<b>C</b>	105	110	120
<b>C2</b>	581	581	581
<b>C4</b>	65	65	65,5
<b>D1</b>	1241	1245	1270,5
<b>E</b>	459	459	459
<b>F</b>	363,5	363,5	363,5

<b>Motor</b>	Brose S-Mag 36, Torque/Coppia: 90 Nm
<b>Battery</b>	Fantic, Lithium Ion, 36 Volt, 720Wh
<b>Display</b>	Brose All Round
<b>Frame</b>	Carbon, sizes: S - M - L
<b>Fork</b>	RockShox Zeb Select 170mm
<b>Shock</b>	RockShox SuperDeluxe Select+
<b>Chain rings</b>	Sram 34t
<b>Crank arm</b>	FSA 165mm
<b>Rear derailleur</b>	Sram GX
<b>Shift Levers</b>	Sram GX AXS Eagle
<b>Cassette</b>	Sram SX, 12V, 11-50
<b>Chain</b>	Sram SX
<b>Brake</b>	Magura MT7 4 Piston disc brake
<b>Brake</b>	Magura MT7 4 Piston disc brake
<b>Disc</b>	Braking S3 Battfly, 220mm - 6Hole
<b>Disc</b>	Braking S3 Battfly, 203mm - 6Hole
<b>Tires</b>	Vittoria E-Martello 29"x 2.35
<b>Tires</b>	Vittoria E-Martello 27,5"x 2.6
<b>Wheels</b>	Fulcrum E-Fire 500 29"-27.5"
<b>Handlebar</b>	Fantic Racing-800mm - Ø35 - Rise 20mm
<b>Stem</b>	Fantic Racing - 50mm - Ø35
<b>Seatpost</b>	Crankbrothers Highline7 Ø 30.9
<b>Saddle</b>	Selle Italia Novus Boost X-Cross Superflow
<b>Note</b>	(*)

## XMf 1.7

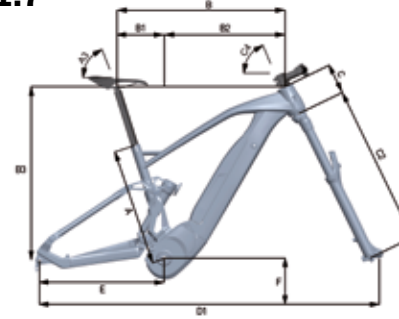

Sizes	S	M	L
<b>A</b>	390	430	490
<b>A3</b>	73	73	73
<b>B</b>	586	596	628
<b>B1</b>	161	162	166
<b>B2</b>	425	454	480
<b>B3</b>	617,8	622,0	633,7
<b>C</b>	105	110	120
<b>C2</b>	581	581	581
<b>C4</b>	65	65	65,5
<b>D1</b>	1241	1245	1270,5
<b>E</b>	459	459	459
<b>F</b>	363,5	363,5	363,5

<b>Motor</b>	Brose S-Mag 36, Torque/Coppia: 90 Nm
<b>Battery</b>	Fantic, Lithium Ion, 36 Volt, 720Wh
<b>Display</b>	Brose All Round
<b>Frame</b>	Aluminum, sizes: S - M - L
<b>Fork (**)</b>	RockShox Domain R 170mm
<b>Shock</b>	RockShox Deluxe Select+
<b>Chain rings</b>	Sram 34t
<b>Crank arm</b>	FSA
<b>Rear derailleur</b>	Sram NX
<b>Shift Levers</b>	Sram NX Eagle
<b>Cassette</b>	Sram SX, 12V, 11-50
<b>Chain</b>	Sram SX
<b>Brake</b>	Sram Guide T 4 Piston disc brake
<b>Brake</b>	Sram Guide T 4 Piston disc brake
<b>Disc</b>	SramCenterLine, 220mm - 6Hole
<b>Disc</b>	SramCenterLine, 200mm - 6Hole
<b>Tires</b>	Vittoria E-Martello 29"x 2.35
<b>Tires</b>	Vittoria E-Martello 27,5"x 2.6
<b>Wheels</b>	Fulcrum E-Fire 700 29"-27.5"
<b>Handlebar</b>	FSA Comet-800mm - Ø35 - Rise 15mm
<b>Stem</b>	FSA Comet-50mm - Ø35 - Rise +6°
<b>Seatpost</b>	Switch SW Ø 30.9 S-M, L
<b>Saddle</b>	Selle Italia Model X Comfort Superflow 145
<b>Note</b>	(*)
<b>Note</b>	(**) Alternative fork / forcella alternativa Suntour Durolox 36

## XEF 1.9 Factory

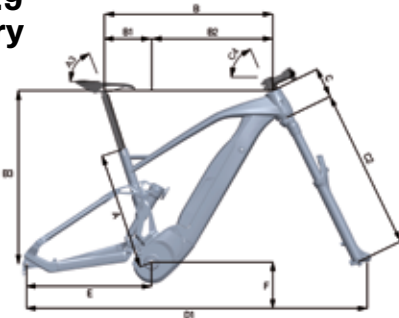

Sizes	S	M	L
<b>A</b>	390	430	490
<b>A3</b>	73	73	73
<b>B</b>	586	596	628
<b>B1</b>	161	162	166
<b>B2</b>	425	454	480
<b>B3</b>	617,8	622,0	633,7
<b>C</b>	105	110	120
<b>C2</b>	581	581	581
<b>C4</b>	65	65	65,5
<b>D1</b>	1241	1245	1270,5
<b>E</b>	459	459	459
<b>F</b>	363,5	363,5	363,5

<b>Motor</b>	Brose S-Mag 36, Torque/Coppia: 90 Nm
<b>Battery</b>	Fantic, Lithium Ion, 36 Volt, 720Wh
<b>Display</b>	Brose Remote
<b>Frame</b>	Aluminum, sizes: S - M - L
<b>Fork</b>	RockShox Zeb Ultimate 190mm
<b>Shock</b>	Ohlins TTX 22M
<b>Chain rings</b>	Sram 34t
<b>Crank arm</b>	FSA
<b>Rear derailleur</b>	Sram GX AXS
<b>Shift Levers</b>	Sram GX AXS Eagle
<b>Cassette</b>	SunRace SilverRed, 12V, 11-51
<b>Chain</b>	Sram NX
<b>Brake</b>	Braking IN.CA.S disc brake
<b>Brake</b>	Braking IN.CA.S disc brake
<b>Disc</b>	Braking S3 Battfly, 220mm - 6Hole
<b>Disc</b>	Braking S3 Battfly, 203mm - 6Hole
<b>Tires</b>	Vittoria E-Mazza 29"x 2.6
<b>Tires</b>	Vittoria E-Martello 27,5"x 2.8
<b>Wheels</b>	Mavic E-Deemax 29"- 27.5"
<b>Handlebar</b>	Fantic Racing-800mm- Ø35 - Rise 20mm -Sand
<b>Stem</b>	Fantic Racing-35mm- Ø35
<b>Seatpost</b>	Crankbrothers HIGHLIGHT7 Ø 30.9
<b>Saddle</b>	Selle Italia Novus Boost X Cross Superflow
<b>Note</b>	(*)

## XEF 1.9 Race

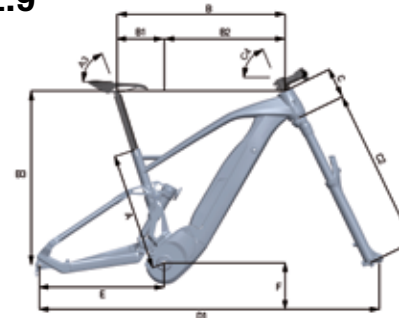

Sizes	S	M	L
<b>A</b>	390	430	490
<b>A3</b>	73	73	73
<b>B</b>	586	596	628
<b>B1</b>	161	162	166
<b>B2</b>	425	454	480
<b>B3</b>	617,8	622,0	633,7
<b>C</b>	105	110	120
<b>C2</b>	581	581	581
<b>C4</b>	65	65	65,5
<b>D1</b>	1241	1245	1270,5
<b>E</b>	459	459	459
<b>F</b>	363,5	363,5	363,5

<b>Motor</b>	Brose S-Mag 36, Torque/Coppia: 90 Nm
<b>Battery</b>	Fantic, Lithium Ion, 36 Volt, 720Wh
<b>Display</b>	Brose Remote
<b>Frame</b>	Aluminum, sizes: S - M - L
<b>Fork (**)</b>	RockShox Zeb Select 190mm
<b>Shock</b>	RockShox SuperDeluxe Coil Select+
<b>Chain rings</b>	Sram 34t
<b>Crank arm</b>	FSA
<b>Rear derailleur</b>	Sram GX
<b>Shift Levers</b>	Sram GX Eagle
<b>Cassette</b>	Sram SX,12V, 11-50
<b>Chain</b>	Sram NX
<b>Brake</b>	Magura MT7 4 Piston disc brake
<b>Brake</b>	Magura MT7 4 Piston disc brake
<b>Disc</b>	Braking S3 Battfly, 220mm - 6Hole
<b>Disc</b>	Braking S3 Battfly, 203mm - 6Hole
<b>Tires</b>	Vittoria E-Mazza 29"x 2.6
<b>Tires</b>	Vittoria E-Martello 27,5"x 2.8
<b>Wheels</b>	Mavic E-Deemax 29"- 27.5"
<b>Handlebar</b>	FSA Gradient-800mm- Ø35 - Rise 15mm
<b>Stem</b>	FSA Gradient-35mm- Ø35 - Rise +6°
<b>Seatpost</b>	Crankbrothers HIGHLIGHT7 Ø 30.9 S-M, L
<b>Saddle</b>	Selle Italia Model-X Bow Superflow
<b>Note</b>	(*)
<b>Note</b>	(**) Alternative fork / forcella alternativa Suntour Durolox 38 180mm

## XE1.9 Carbon Team

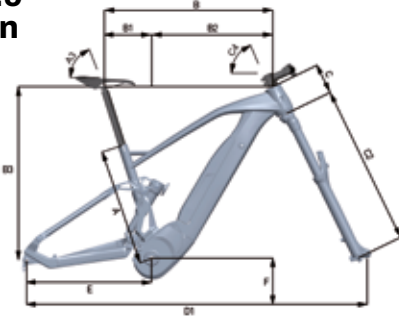

Sizes	S	M	L
<b>A</b>	390	430	490
<b>A3</b>	73	73	73
<b>B</b>	586	596	628
<b>B1</b>	161	162	166
<b>B2</b>	425	454	480
<b>B3</b>	617,8	622,0	633,7
<b>C</b>	105	110	120
<b>C2</b>	581	581	581
<b>C4</b>	65	65	65,5
<b>D1</b>	1241	1245	1270,5
<b>E</b>	459	459	459
<b>F</b>	363,5	363,5	363,5

<b>Motor</b>	Brose S-Mag 36, Torque/Coppia: 90 Nm
<b>Battery</b>	Fantic, Lithium Ion, 36 Volt, 720Wh
<b>Display</b>	Brose All Round
<b>Frame</b>	Carbon, sizes: S - M - L
<b>Fork</b>	RockShox Zeb Ultimate, 190mm
<b>Shock</b>	RockShox SuperDeluxe Coil Select+, 205x65mm, 450lb spring
<b>Chain rings</b>	Sram Eagle 34t
<b>Crank arm</b>	FSA 170mm
<b>Rear derailleur</b>	Sram GX Eagle 12V
<b>Shift Levers</b>	Sram GX Eagle
<b>Cassette</b>	Sram SX Eagle 11-50
<b>Chain</b>	Sram NX Eagle
<b>Brake</b>	Magura MT7 4 Piston disc brake
<b>Brake</b>	Magura MT7 4 Piston disc brake
<b>Disc</b>	Braking S3 Battfly 220/F, 203/R
<b>Disc</b>	Braking S3 Battfly, 203mm - 6Hole
<b>Tires</b>	Vittoria E-MAZZA 29"x 2.6
<b>Tires</b>	Vittoria E-Martello 27,5"x 2.6
<b>Wheels</b>	MAVIC E-DEEMAX 29"-27.5"
<b>Handlebar</b>	FSA Gradient Ø35 800mm Rise 25mm
<b>Stem</b>	FSA Gradient Ø35 x 35mm +6°
<b>Seatpost</b>	SWITCH SW Ø30.9
<b>Saddle</b>	Selle Italia Novus Boost Evo Superflow
<b>Note</b>	(*)

## XM1.7

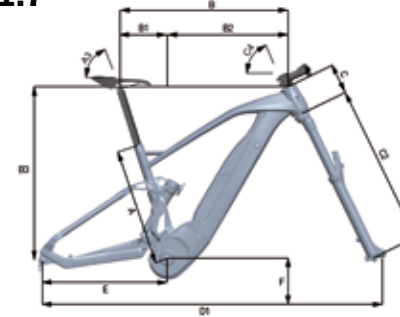

Sizes	S	M	L
<b>A</b>	390	430	490
<b>A3</b>	73	73	73
<b>B</b>	586	596	628
<b>B1</b>	161	162	166
<b>B2</b>	425	454	480
<b>B3</b>	617,8	622,0	633,7
<b>C</b>	105	110	120
<b>C2</b>	581	581	581
<b>C4</b>	65	65	65,5
<b>D1</b>	1241	1245	1270,5
<b>E</b>	459	459	459
<b>F</b>	363,5	363,5	363,5

<b>Motor</b>	Brose S-Mag 36, Torque/Coppia: 90 Nm
<b>Battery</b>	Fantic, Lithium Ion, 36 Volt, 720Wh
<b>Display</b>	Brose All Round
<b>Frame</b>	Aluminum, sizes: S - M - L
<b>Fork (**)</b>	RockShox Domain R 170mm
<b>Shock</b>	RockShox Deluxe Select+
<b>Chain rings</b>	Sram 34t
<b>Crank arm</b>	FSA
<b>Rear derailleur</b>	Sram NX
<b>Shift Levers</b>	Sram NX Eagle
<b>Cassette</b>	Sram SX, 12V, 11-50
<b>Chain</b>	Sram SX
<b>Brake</b>	Sram Guide T 4 Piston disc brake
<b>Brake</b>	Sram Guide T 4 Piston disc brake
<b>Disc</b>	SramCenterLine, 220mm - 6Hole
<b>Disc</b>	SramCenterLine, 200mm - 6Hole
<b>Tires</b>	Vittoria E-Martello 29"x 2.35
<b>Tires</b>	Vittoria E-Martello 27,5"x 2.6
<b>Wheels</b>	Fulcrum E-Fire 700 29"-27.5"
<b>Handlebar</b>	FSA Comet-800mm - Ø35 - Rise 15mm
<b>Stem</b>	FSA Comet-50mm - Ø35 - Rise +6°
<b>Seatpost</b>	Switch SW Ø 30.9 S-M, L
<b>Saddle</b>	Selle Italia Model X Comfort Superflow 145
<b>Note</b>	(*)
<b>(**)</b>	Alternative fork / forcella alternativa Suntour Durolux 36

## XE1.9 Factory

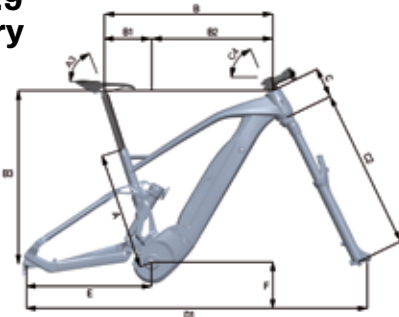

Sizes	S	M	L
<b>A</b>	390	430	490
<b>A3</b>	73	73	73
<b>B</b>	586	596	628
<b>B1</b>	161	162	166
<b>B2</b>	425	454	480
<b>B3</b>	617,8	622,0	633,7
<b>C</b>	105	110	120
<b>C2</b>	581	581	581
<b>C4</b>	65	65	65,5
<b>D1</b>	1241	1245	1270,5
<b>E</b>	459	459	459
<b>F</b>	363,5	363,5	363,5

<b>Motor</b>	Brose S-Mag 36, Torque/Coppia: 90 Nm
<b>Battery</b>	Fantic, Lithium Ion, 36 Volt, 720Wh
<b>Display</b>	Brose Remote
<b>Frame</b>	Aluminum, sizes: S - M - L
<b>Fork</b>	RockShox Zeb Ultimate 190mm
<b>Shock</b>	Ohlins TTX 22M
<b>Chain rings</b>	Sram 34t
<b>Crank arm</b>	FSA
<b>Rear derailleur</b>	Sram GX AXS
<b>Shift Levers</b>	Sram GX AXS Eagle
<b>Cassette</b>	SunRace SilverRed, 12V, 11-51
<b>Chain</b>	Sram NX
<b>Brake</b>	Braking IN.CA.S disc brake
<b>Brake</b>	Braking IN.CA.S disc brake
<b>Disc</b>	Braking S3 Battfly, 220mm - 6Hole
<b>Disc</b>	Braking S3 Battfly, 203mm - 6Hole
<b>Tires</b>	Vittoria E-Mazza 29"x 2.6
<b>Tires</b>	Vittoria E-Martello 27,5"x 2.8
<b>Wheels</b>	Mavic E-Deemax 29"-27.5"
<b>Handlebar</b>	Fantic Racing-800mm- Ø35 - Rise 20mm -Sand
<b>Stem</b>	Fantic Racing-35mm- Ø35
<b>Seatpost</b>	Crankbrothers HIGHLIGHT7 Ø 30.9
<b>Saddle</b>	Selle Italia Novus Boost X Cross Superflow
<b>Note</b>	(*)

## XXF 2.0 Factory

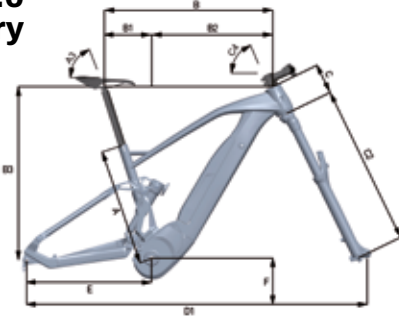

Sizes	S	M	L
<b>A</b>	390	430	490
<b>A3</b>	73	73	73
<b>B</b>	586	596	628
<b>B1</b>	161	162	166
<b>B2</b>	425	454	480
<b>B3</b>	617,8	622,0	633,7
<b>C</b>	105	110	120
<b>C2</b>	581	581	581
<b>C4</b>	65	65	65,5
<b>D1</b>	1241	1245	1270,5
<b>E</b>	459	459	459
<b>F</b>	363,5	363,5	363,5

<b>Motor</b>	Brose S-Mag 36, Torque/Coppia: 90 Nm
<b>Battery</b>	Fantic, Lithium Ion, 36 Volt, 720Wh
<b>Display</b>	Brose Remote
<b>Frame</b>	Aluminum, sizes: S - M - L
<b>Fork</b>	Ohlins DH 38 200mm
<b>Shock</b>	Ohlins TTX 22M
<b>Chain rings</b>	Sram 34t
<b>Crank arm</b>	FSA
<b>Rear derailleur</b>	Sram GX
<b>Shift Levers</b>	Sram GX Eagle
<b>Cassette</b>	SunRace SilverRed, 12V, 11-51
<b>Chain</b>	Sram NX
<b>Brake</b>	Braking IN.CA.S disc brake
<b>Brake</b>	Braking IN.CA.S disc brake
<b>Disc</b>	Braking S3 Battfly, 220mm - 6Hole
<b>Disc</b>	Braking S3 Battfly, 203mm - 6Hole
<b>Tires</b>	Vittoria E-Mazza 29"x 2.6
<b>Tires</b>	Vittoria E-Martello 27,5"x 2.8
<b>Wheels</b>	Mavic E-Deemax 29"- 27.5"
<b>Handlebar</b>	Fantic Racing-800mm- Ø35 - Rise 30mm -Sand
<b>Stem</b>	Fantic Racing Diretto -35mm- Ø35
<b>Seatpost</b>	Crankbrothers HIGHLIGHT7 Ø 30.9
<b>Saddle</b>	Selle Italia Novus Boost X Cross Superflow
<b>Note</b>	(*)

## Fat Sport

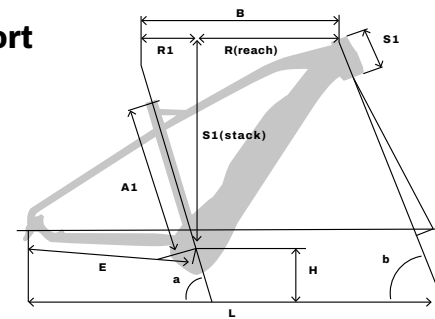

Sizes	S	M	L
<b>A</b>	410	450	490
<b>B</b>	584	605	630
<b>E</b>	490	490	490
<b>H</b>	324	324	324
<b>H1</b>	56	56	56
<b>L</b>	1175	1179	1187
<b>R</b>	406	418	422
<b>R1</b>	175	187,5	207,5
<b>S</b>	610	613	638
<b>S1</b>	120	120	145
<b>a</b>	74°	73°	72°
<b>b</b>	68°	68,5°	69°

<b>Motor</b>	Brose T-Alu, Torque/Coppia: 70 Nm
<b>Battery</b>	Fantic, Lithium Ion, 36 Volt, 630Wh
<b>Display</b>	Brose All Round
<b>Frame</b>	Aluminium, sizes: S - M - L
<b>Fork</b>	RockShox Bluto, 120mm
<b>Crankarm</b>	Miranda
<b>Groupset</b>	Sram SX
<b>Cassette</b>	Sram SX Eagle 12V 11-50
<b>Chain</b>	Sram SX
<b>Front brake</b>	Sram Level, 2P, Hydraulic Disc Brake, 200mm disc
<b>Rear brake</b>	Sram Level, 2P, Hydraulic Disc Brake, 180mm disc
<b>Tires</b>	Schwalbe Jumbo-Jim, 26 X 4"
<b>Wheels</b>	Gipiemme 26"
<b>Front hub</b>	Gipiemme thru axle 15mm
<b>Rear hub</b>	Gipiemme thru axle 12mm
<b>Handlebar</b>	FSA Ø31,8 -760m- Rise 15mm
<b>Stem</b>	FSA Logo - Ø31,8 - 60mm - Rise ±6°
<b>Seatpost</b>	FSA Ø30.9
<b>Saddle</b>	Selle Italia Model X Comfort superflow
<b>Note</b>	(*)

## Integra XF2

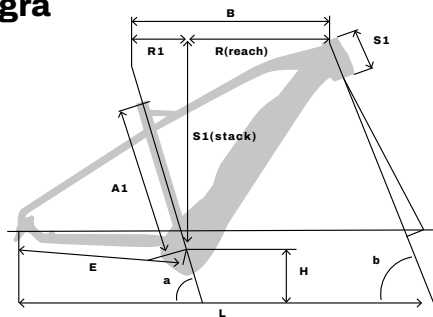

Sizes	S	M	L
<b>A</b>	410	450	490
<b>B</b>	584	605	630
<b>E</b>	490	490	490
<b>H</b>	324	324	324
<b>H1</b>	56	56	56
<b>L</b>	1175	1179	1187
<b>R</b>	406	418	422
<b>R1</b>	175	187,5	207,5
<b>S</b>	610	613	638
<b>S1</b>	120	120	145
<b>a</b>	74°	73°	72°
<b>b</b>	68°	68,5°	69°

<b>Motor</b>	Brose T-Alu, Torque/Coppia: 70 Nm
<b>Battery</b>	Fantic, Lithium Ion, 36 Volt, 630Wh
<b>Display</b>	Brose All Round
<b>Frame</b>	Aluminium, sizes: S - M - L
<b>Fork</b>	RockShox Recon Silver RL, 120mm
<b>Crankarm</b>	Miranda
<b>Groupset</b>	Sram SX Eagle
<b>Cassette</b>	Sram SX,12V, 11-50
<b>Chain</b>	Sram SX
<b>Front brake</b>	Sram Level, 2P, Hydraulic Disc Brake, 200mm disc
<b>Rear brake</b>	Sram Level, 2P, Hydraulic Disc Brake, 180mm disc
<b>Tires</b>	Vittoria Barzo, front 29"x 2.25" / Rear 27.5" x 2.6"
<b>Wheels</b>	Gipiemme, tubeless ready
<b>Front hub</b>	Gipiemme N28, 110mm, boost, thru axle 15mm
<b>Rear hub</b>	Gipiemme N33, 148mm, boost, thru axle 12mm
<b>Handlebar</b>	FSA Ø31,8 -760m- Rise 15mm
<b>Stem</b>	FSA Logo - Ø31,8 - 60mm - Rise ±6°
<b>Seatpost</b>	FSA
<b>Saddle</b>	Selle Italia Model X Comfort superflow
<b>Note</b>	(*)

## Living Urban



Sizes	S	M	L
A	430	460	500
A2	72	72	72
B	575	600	625
B1	201	201	207
Reach	374	399	418
Stack	618	618	637
W	27,5"	28"	28"
C	150	150	170
C1	2	2	2
C2	460	460	460
C3 Trail	84,15	92,2	92,2
C4	69	69	69
R	44	44	44
D	637,5	662	688
D1	1101	1126	1152,5
D2	1785	1854	1880,5
E	471,2	471,2	471,2
E1	467	467	467
F	279	301	301
F1	63	63	63
Lever	170	170	170
Stem	100	100	100
Bar	700	700	700
Regg.	350	350	350

<b>Motor</b>	Yamaha PW S2, Torque/Coppia: 75Nm
<b>Battery</b>	Fantic, Lithium Ion, 36 Volt, 630Wh
<b>Display</b>	Display B Yamaha
<b>Frame</b>	Aluminium, sizes: S - M - L
<b>Fork</b>	RST Volant, travel 50mm
<b>Groupset</b>	Enviolo City
<b>Crankarm</b>	FSA
<b>Front brake</b>	Promax Solve ST 925 hydraulic 2P, 180mm disc
<b>Rear brake</b>	Promax Solve ST 925 hydraulic 2P, 180mm disc
<b>Tires</b>	Vittoria E-Randonneur
<b>Rim and Spokes</b>	GBC 29" (M-L) - 27.5" (S)
<b>Front hub</b>	GBC, 110mm Boost
<b>Rear hub</b>	GBC, 148mm Boost
<b>Handlebar</b>	GBC 700mm, Rise 20mm
<b>Stem</b>	GBC 70mm
<b>Saddle</b>	Selle Italia T3 Flow
<b>Seatpost</b>	Promax Suspended Ø30.9
<b>Pedals</b>	Aluminium
<b>Front light</b>	Busch Muller
<b>Rear light</b>	Trelock
<b>Locker</b>	Abus
<b>Note</b>	(*)

## Living Urban Easy



Sizes	S	M	L
A	430	460	500
A2	72	72	72
B	575	600	625
B1	201	201	207
Reach	374	399	418
Stack	618	618	637
W	27,5"	28"	28"
C	150	150	170
C1	2	2	2
C2	460	460	460
C3 Trail	84,15	92,2	92,2
C4	69	69	69
R	44	44	44
D	637,5	662	688
D1	1101	1126	1152,5
D2	1785	1854	1880,5
E	471,2	471,2	471,2
E1	467	467	467
F	279	301	301
F1	63	63	63
Lever	170	170	170
Stem	100	100	100
Bar	700	700	700
Regg.	350	350	350

<b>Motor</b>	Yamaha PW S2, Torque/Coppia: 75Nm
<b>Battery</b>	Fantic, Lithium Ion, 36 Volt, 630Wh
<b>Display</b>	Display A Yamaha / Display B Yamaha (depending on availability)
<b>Frame</b>	Aluminium, sizes: S - M - L
<b>Fork</b>	Suntour XCR34, travel 100mm
<b>Groupset</b>	SRAM SX Eagle
<b>Crankarm</b>	FSA
<b>Front brake</b>	Promax Solve ST 925 hydraulic 2P, 180mm disc
<b>Rear brake</b>	Promax Solve ST 925 hydraulic 2P, 180mm disc
<b>Tires</b>	Vittoria E-Randonneur
<b>Rim and Spokes</b>	GBC 29" (M-L) - 27.5" (S)
<b>Front hub</b>	GBC, 110mm Boost
<b>Rear hub</b>	GBC, 148mm Boost
<b>Handlebar</b>	GBC 700mm, Rise 20mm
<b>Stem</b>	GBC 70mm
<b>Saddle</b>	Selle Italia MAX S5 Superflow
<b>Seatpost</b>	Switch Suspended Ø30.9
<b>Pedals</b>	Aluminium
<b>Front light</b>	Busch Muller
<b>Rear light</b>	Trelock
<b>Locker</b>	Abus
<b>Note</b>	(*)

## Seven Days Living



Sizes	S	M	L
A	430	460	500
A2	72	72	72
B	575	600	625
B1	201	201	207
Reach	374	399	418
Stack	618	618	637
W	27,5"	28"	28"
C	150	150	170
C1	2	2	2
C2	460	460	460
C3 Trail	84,15	92,2	92,2
C4	69	69	69
R	44	44	44
D	637,5	662	688
D1	1101	1126	1152,5
D2	1785	1854	1880,5
E	471,2	471,2	471,2
E1	467	467	467
F	279	301	301
F1	63	63	63
Lever	170	170	170
Stem	100	100	100
Bar	700	700	700
Regg.	350	350	350

<b>Motor</b>	Brose T-Alu, Torque/Coppia: 70Nm
<b>Battery</b>	Fantic, Lithium Ion, 36 Volt, 630Wh
<b>Display</b>	Brose All Round
<b>Frame</b>	Aluminium, sizes: S - M - L
<b>Fork</b>	RockShox Recon 29, 100mm
<b>Groupset</b>	SRAM SX Eagle
<b>Crankarm</b>	Miranda
<b>Front brake</b>	SRAM Level steel hydraulic 2P, 180mm disc
<b>Rear brake</b>	SRAM Level steel hydraulic 2P, 180mm disc
<b>Tires</b>	Vittoria E-Randonneur
<b>Rim and Spokes</b>	GBC, Aluminium, 28"
<b>Front hub</b>	GBC, 110mm Boost
<b>Rear hub</b>	GBC, 148mm Boost
<b>Handlebar</b>	GBC Over Back - 680mm, RISE 25mm
<b>Stem</b>	GBC AHEAD Set over - 70MM
<b>Saddle</b>	Selle Italia ST 5 GF
<b>Seatpost</b>	Promax Suspended Ø30.9
<b>Pedals</b>	Aluminium
<b>Front light</b>	Busch Muller
<b>Rear light</b>	Trelock
<b>Locker</b>	Abus
<b>Note</b>	(*)

## Seven Days Living Easy



Sizes	S	M	L
A	430	460	500
A2	72	72	72
B	575	600	625
B1	201	201	207
Reach	374	399	418
Stack	618	618	637
W	27,5"	28"	28"
C	150	150	170
C1	2	2	2
C2	460	460	460
C3 Trail	84,15	92,2	92,2
C4	69	69	69
R	44	44	44
D	637,5	662	688
D1	1101	1126	1152,5
D2	1785	1854	1880,5
E	471,2	471,2	471,2
E1	467	467	467
F	279	301	301
F1	63	63	63
Lever	170	170	170
Stem	100	100	100
Bar	700	700	700
Regg.	350	350	350

<b>Motor</b>	Brose T, Torque/Coppia: 70Nm
<b>Battery</b>	Fantic, Lithium Ion, 36 Volt, 630Wh
<b>Display</b>	Brose All Round
<b>Frame</b>	Aluminium frame. Sizes: S/M - L/XL
<b>Fork</b>	RockShox Recon 29, 100mm
<b>Groupset</b>	SRAM SX Eagle
<b>Crankarm</b>	Miranda
<b>Front brake</b>	SRAM Level steel hydraulic 2P, 180mm disc
<b>Rear brake</b>	SRAM Level steel hydraulic 2P, 180mm disc
<b>Tires</b>	Vittoria E-Randonneur 50mm
<b>Rim and Spokes</b>	GBC 29" (M-L) - 27.5" (S)
<b>Front hub</b>	GBC, 110mm Boost
<b>Rear hub</b>	GBC, 148mm Boost
<b>Handlebar</b>	GBC Over Back - 680mm, RISE 25mm
<b>Stem</b>	GBC AHEAD Set over - 70MM
<b>Saddle</b>	Selle Italia ST 5 GF
<b>Seatpost</b>	Promax Suspended Ø30.9
<b>Pedals</b>	Aluminium
<b>Front light</b>	Busch Muller
<b>Rear light</b>	Trelock
<b>Locker</b>	Abus
<b>Note</b>	(*)



**Fantic,**  
we design,  
engineer  
and assemble  
high-performance  
electric bikes.



@fanticbikes



Fantic Bikes



Fantic Bikes



Fantic Motor



@fanticmotor\_official